

WARNING

- Do NOT operate this machine before reading the INSTRUCTION MANUAL.
- Do Not operate this machine unless you are competent and have received training.
- This machine is designed for digging post holes and driving fence posts ONLY. (Please contact Lyco Parts and Service if in doubt regarding your application)
- NO part of the human body should be placed inside the safety guard, near the auger or under the 'hammer' during operation.
- Do NOT wear loose fitting clothes or untied long hair while operating the machine.
- Do NOT operate machine unless all safety systems and guards are operational.
- If ANY part of the machine is not fully operational please contact Lyco Parts and Service for advice BEFORE operating the machine.

Munro Engineers Pty. Ltd.

418-420 Winter St
Ballarat 3350

Telephone: +61 3 5334 2770

Fax: +61 3 5334 2755

Email: sales@munroeng.com

Website: www.munroeng.com

**FAILURE TO COMPLY WITH THESE INSTRUCTIONS
MAY RESULT IN DEATH OR SERIOUS INJURY.**

CONTENTS

<u>WARNING</u>	1
CONTENTS	2
SAFETY RULES	4
OH&S COMPLIANCE	5
WARRANTY	6
PROCEDURE FOR WARRANTY CLAIMS ON LYCO PRODUCTS.	7
PARTS AND ASSEMBLY	8
PARTS.....	8
ASSEMBLY.....	8
<i>UNPACKING</i>	8
<i>ATTACHMENT TO YOUR TRACTOR</i>	8
MODIFICATION TO FILLER PLUG – FOR ATTACHING THE RETURN OIL HOSE.....	9
FRONT GUARD.....	10
SETTING THE MAST VERTICALLY	10
OPERATION	12
VALVE CONTROLS	12
HAMMER AND HAMMER CONTROL	13
AUGER ATTACHMENT AND CONTROL	13
TILTS AND TILT CONTROLS	15
DRIVING POSTS	15
SAFTY INSPECTIONS, MAINTENANCE AND SERVICING SCHEDULE.	17
OPTIONS	18
HIGHLIFT.....	18
SIDE-SHIFT.....	19
SPECIFICATIONS	21
SERVICE AND REPAIR	22
INDEX	23

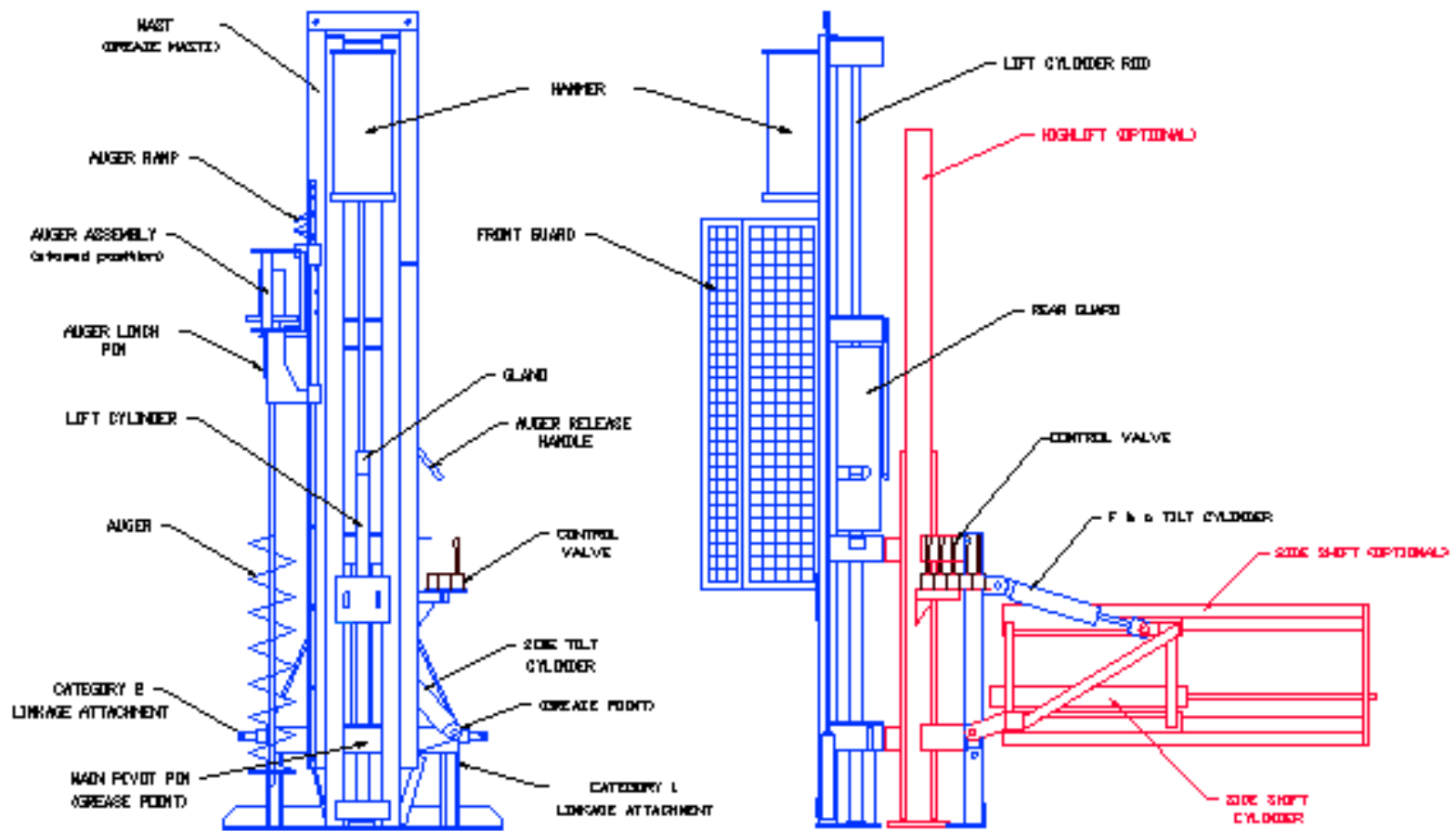

Figure 1 - Assembly Diagram

SAFETY RULES

- **Do not operate post driver without guards fitted and in the operating position.**
- **Do not guide post being driven with hands - use bar and chain provided. Please note: chain is not to be hooked back to the main frame when driving posts.**
- **Do not operate post driver with damaged hydraulic hoses.**
- **Check all pivot pins, lynch pins and cylinder clevises regularly for wear, damage and integrity.**
- **Do not leave the hammer in the raised position when travelling or at any other time, except while in the process of driving posts.**
- **Keep feet clear of post driver base when operating machine on tractor three point linkage arms.**
- **Do not operate post driver without attaching and adjusting three point linkage stabiliser chains on tractor, to limit sideways movement.**
- **Do not travel if auger is not securely locked in stowing position.**

OH&S COMPLIANCE

Lyco Innovations Pty Ltd

Statement of Product OH&S Compliance

A hazard identification, risk assessment and risk control procedure has been carried out on a representative example of the product detailed below, in accordance with the Occupational Health and Safety requirements of all states and territories of Australia, and where found necessary, the appropriate risk control measures have been incorporated in the product specifications.

The operators manual contains the necessary health and safety information and safety warnings are applied to the product where necessary.

Product Description: **Powerhouse**

Model/s: **Post Driver**

Signed on behalf of Lyco Innovations Pty Ltd



Richard A Davis
Value Engineer
26/ 07/2006

The following unit was assessed for the purpose of compliance.

Model No: **1,2 & 3**
Hi Lift

Serial No: **4624**
4807

Date of inspection: **01 /10 /2001**
22 /08 /2002

Location: **Beaufort**

WARRANTY

Product Warranty.

Lycos Innovations warrant to the owner of each new product sold that for the specified period commencing from the date of purchase, that at its discretion, Lycos will repair or replace, free of charge, any product or component found to be defective in materials and/or workmanship. The standard product warranty period is for 12 months or 1040 hours of operation, whichever occurs first. Warranty periods different to this are specified on Lycos Innovations sales brochures.

This warranty shall exclude defects occurring through incorrect or inappropriate: storage, transport, non Lycos design, application, use, or, accident, or, wilful damage, or as a result of unauthorised or incompetent servicing by other than Lycos' staff or authorised persons.

Notwithstanding any statutory obligations under certain legislation, including the Trade Practices Act prevailing in the state or territory the product was sold, Lycos accepts no liability for any consequential loss or damage due to product failure or late delivery, and limits any liability that it might nevertheless have to a maximum amount being the invoiced price of the product.

To ensure ongoing warranty cover subsequent owners must notify Lycos in writing stating: the product, the serial number and the date of purchase.



Richard J. Lyons.
Managing Director.

PROCEDURE FOR WARRANTY CLAIMS ON LYCO PRODUCTS.

1. All claims for warranty must be authorised by Lyco Innovations prior to any warranty repairs commencing. Customers wanting to claim warranty must provide the following details in writing: date and proof of purchase (or have returned the "Guarantee Registration Card") the serial and/or identification number(s) of the product, and, the reason for such claim.
2. A unique warranty number will be issued to the customer or an agent of Lycos choice. This warranty number must be clearly labelled on all product returned for warranty assessment. Product received not clearly labelled with the warranty number will be returned direct to the sender.
3. If Lyco accepts the warranty claim, an "Application for Warranty" form will be raised, authorising warranty repairs. The repair time frame will be confirmed at this point. For sub contract repairs, the Application for Warranty form needs to be completed and accompany any invoice for the warranty claim.
4. Lyco will pay the cost of parts and/or reasonable costs of labour actually incurred in repairing the faulty component(s) by the customer or an agent. Usually Lyco will supply any replacement parts from its own stock. Warranty repairs will be completed to Lyco Innovations satisfaction.
5. Non warranty work will be repaired and charged out at commercial rates.
6. Freight and postage incurred to complete warranty claims is the responsibility of the customer. Freight should be with Lyco Innovations nominated carrier, as Lyco will only reimburse freight costs incurred with Lycos nominated carrier.
7. Travelling for warranty work is the responsibility of the customer. In its absolute discretion Lyco may pay travelling costs associated with the warranty claim. No labour will be paid for the time that travelling is claimed.
8. Warranty claims for products damaged in freight will not be accepted. The risk for damage, loss or delays in freight is the sole responsibility of the buyer. This is detailed in section 5.1 of the "Terms and Conditions of Sale" document (Credit Application). The only exception to this is where insurance has been taken out and paid for by the buyer, or, other written arrangements have been agreed with Lyco Innovations at time of order.

Note: Insurance is available from Lyco at 0.5% of invoice value, which covers replacement of damaged items.
9. Replaced parts and components are the property of Lyco Parts & Service Division. Replaced parts are to be returned to Lyco as directed on the "Application for Warranty" form.

PARTS AND ASSEMBLY

PARTS

Included with the post driver are the following parts:

- Crow Bar
- 7 ft. (2.1 m) x 1" (25mm) I.D. Plastic oil return hose with hose clamps
- Bolt for securing the Front Guard in the extended position.
- Augers (where applicable)
- Auger clip (where applicable)
- Instruction Manual

ASSEMBLY

UNPACKING

Upon receipt of your Lyco "PowerHouse" Post Driver remove all wire ties and packaging material. Check for any damage that may have occurred during transit from the factory. Please notify both the carrier and supplier within 3 days if any parts are missing or damaged.

ATTACHMENT TO YOUR TRACTOR

The Post Driver can be operated on Category 1 or 2 three-point linkage tractors fitted with live hydraulics. The post driver is supplied with a pressure line that is coupled to one outlet of the tractor's remote control hydraulics. The customer is responsible for supplying the break-away coupling to suit the tractor the post driver is to be fitted to. The return oil line from the post driver is connected into the filler plug located at the rear of most tractors. See MODIFICATION INSTRUCTIONS on page 10. It is important there is no restriction to oil flow in this line, as maximum performance is dependent on the free return of oil to the tractor's transmission. Note: The Oil Return Line Must Not Be Connected To The Remote Outlet.

MODIFICATION TO FILLER PLUG – FOR ATTACHING THE RETURN OIL HOSE

1. Use the existing tractor rear transmission filler plug. Drill $\frac{3}{4}$ " diameter hole through plug.
2. Counter bore $1 \frac{1}{16}$ " (27mm) diameter hole approx. $\frac{1}{4}$ " deep from outside surface.
3. Weld in $\frac{3}{4}$ " B.S.P. threaded pipe 50mm long. Do not use galvanised pipe.
4. Supply $\frac{3}{4}$ " B.S.P. end cap to seal hydraulic system when post driver is removed from the tractor. Refer to Figure 2 below.

Note: This modification may not suit all applications. Contact your local tractor dealer for details on the most suitable modifications.

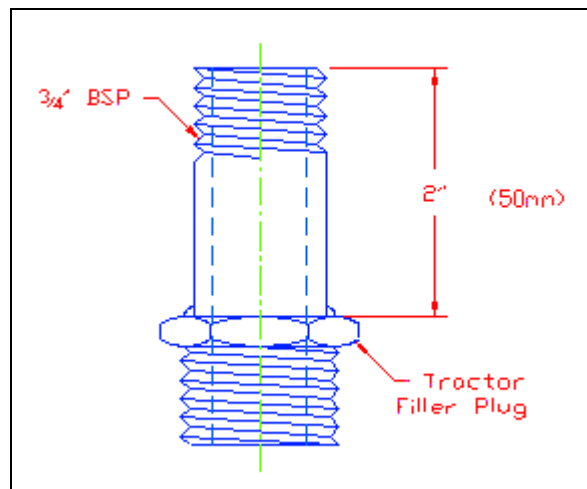

Figure 2 - Modification to Filler Plug

FRONT GUARD

1. Rotate the front guard to the extended position, as shown in Figure 3 on Page 9.
2. Fit the $\frac{1}{4}$ " bolt through the hole in the bottom of the guard pivot, as shown in Figure 3 on Page 9.

Safety Note: The front guard **must** be positioned correctly before the post driver is operated.

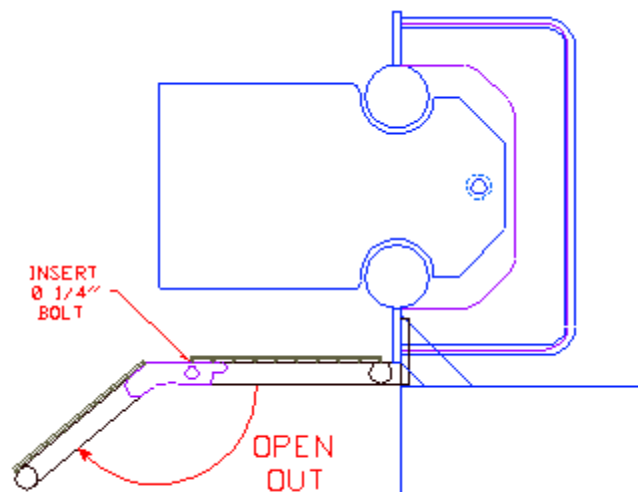

Figure 3 - Guard Attachment – Top down view

SETTING THE MAST VERTICALLY

When fitting the post driver to your tractor you may experience some difficulty in setting the mast vertically with the top link cylinder in mid-stroke position. With most tractors an 8" top link cylinder in mid-stroke will position the mast vertically, however, if this is not the case the following options are available.

1. If the mast lays back towards the tractor, i.e. top link too short.

If the top link is too short an extension is required. To determine this extension, extend the cylinder until the mast is vertical and measure the eye-to-eye length of the cylinder. Subtract 24" (614mm) ($\frac{1}{2}$ stroke eye to eye length of an 8" cylinder) to give the extension required. NOTE: Contact the Parts and Service Division for further assistance or alternatively – fit a cylinder that has a 10" or 12" stroke.

2. If the mast lays away from the tractor, i.e. top link too long.

Exchange the 8" cylinder for a 6" cylinder. The $\frac{1}{2}$ stroke eye-to-eye length is 22.25" (538mm) which is 3" shorter than the 8" cylinder. This will of course then limit the tilt to 17.5° total. If the 6" cylinder is still too long or if you prefer to retain the 8" cylinder for its extra angular adjustment, the extension lugs can be removed from the A-Frame. These can be cut off, however there is a possibility of fouling problems with the base of the cylinder on the vertical members of the A-Frame.

NOTE: Linkage extensions are available for some applications. These are available in 100,150 and 200mm lengths. These position the "A" frame further away from the tractor and enable the standard 8" top link cylinder to be retained. Thus not limiting the Fore and Aft tilt to less than 12.5°. Contact the Parts and Service Division for further assistance.

OPERATION

VALVE CONTROLS

The Hydraulic control valve is an Oilpath mono-bloc valve with four spools for No.2 models and five spools for No.1 models. The valve spools control:

- Hammer Movement
- Auger Rotation
- Side Tilt Movement
- Fore & Aft Tilt Movement
- Side Shift / Highlift (if option fitted)

The Figure below shows the valve set-up.

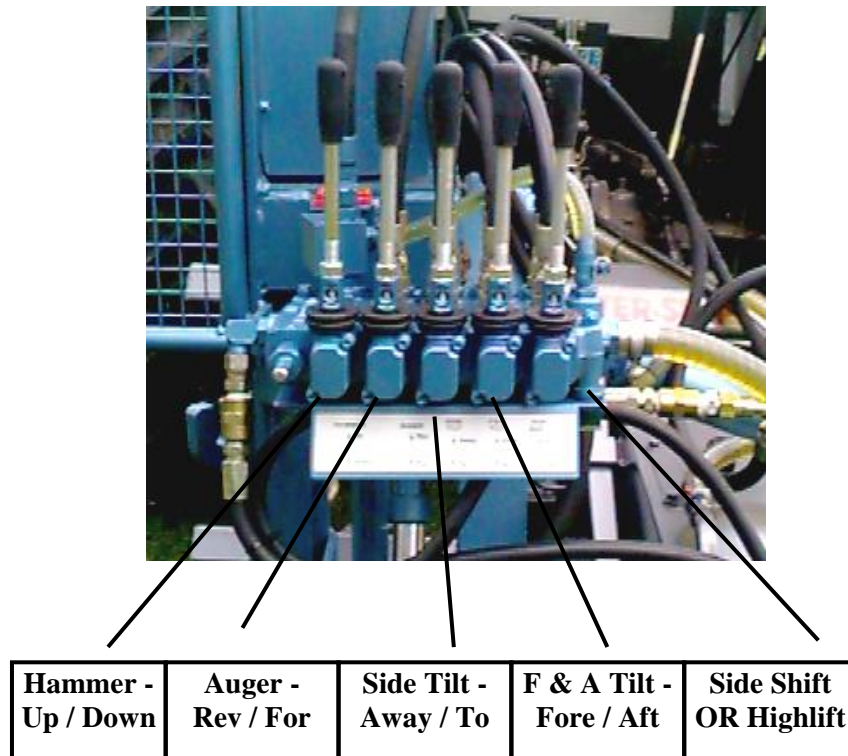

Figure 4 - Valve Controls

HAMMER AND HAMMER CONTROL

The 535lb (244kg) solid steel hammer is hydraulically raised and cushioned at the full extent of its stroke. The slide configuration of the hammer is a well proven method of providing maximum bearing surface and can be expected to give years of trouble-free service.

The control valve spool positions are arranged so as to enable best use to be made of the excellent flow characteristics of the valve. Thus, as the operator stands facing the control valve, the operating lever to the extreme left activates the hammer by movement away from the operator to lift and towards to lower. The operator has full control over the ascent and descent of the hammer. As a safety feature the hammer can be halted at any point by releasing the lever. The shock relief valve will protect the lift cylinder, hoses, fittings and the control valve from failing due to pressure spikes from normal operation. **Safety Note: Do not leave the hammer in the raised position, especially if the PD is left unattended.**

NOTE: It is recommended that the mast tubes be lubricated with graphite grease to reduce friction. In dusty conditions remove old grease and replenish with new grease regularly.

AUGER ATTACHMENT AND CONTROL

The auger assembly is mounted to the slide bar located on the mast stiffeners. The slide tube assembly allows for both rotational and vertical movement of the auger assembly. The auger assembly is normally kept in the 'stowed' position. When the auger is required for use, the hammer should be raised to its highest position. Pull the release handle, as shown in Figure 5 below, and the auger assembly will automatically rotate around onto the mast ready for attachment.

NOTE: The Mast must be in vertical position for this operation.



Figure 5 - Auger Carrier Release Handle

Lower the hammer firmly until the attaching latches are engaged. The auger can now be inserted into the drive shaft socket. Insert the auger and fasten with the auger clip provided, see the Figure 6 below.



Figure 6 -

Attachment

Auger

The hammer can now be lowered until the auger tip contacts the ground. The auger is operated using the lever on the valve labelled 'AUGER'. Pulling the lever towards yourself operates the auger in the clockwise direction; conversely pushing the lever away operates the auger in the reverse direction.

Safety Note: Ensure that your feet are not under the descending auger and that you are behind the front guard while operating the auger.

For safety reasons, operator attendance is required while drilling the pilot hole. Rotary motion of the auger will cease when the control lever is released. While operating the lever, occasionally 'crack' the hammer control lever to allow the weight of the hammer to push the auger into the ground a little at a time. The applications of excessive weight by allowing the full weight of the hammer on to the auger can, in some conditions, cause the auger to stall. This may be due to the auger 'cork-screwing' into the earth in soft or wet conditions or stalling in very hard conditions. The auger will dig a hole directly under the hammer to any depth up to 3'3" (990mm).

To disengage the auger assembly, raise the hammer to its upper most position. The auger assembly will automatically disengage and return to its 'stowed' position ready for the next application. Lower the hammer to the rest position.

NOTE: The auger assembly connection and release operations have been designed to work effectively when the post driver mast is directly vertical. If the post driver is not operated in this position, the auger carrier may not engage and disengage effectively.

TILTS AND TILT CONTROLS

When the tilt options are fitted the mast can be adjusted between 8°-12.5° either side of vertical (depending on top link cylinder stroke length) in the fore and aft plane and 13° either side of vertical for side tilt. This enables vertical positioning of the mast in most terrain. For best results adjust tractor linkage stabilisers to reduce sideways movement of the "A" frame.

DRIVING POSTS

Posts may be driven directly into the ground or a pilot hole may be dug first depending on soil conditions. Pilot hole size depends on ground geology & moisture content, shape and size of posts. As a guide, an auger 1"- 2" (25mm-50mm) smaller than the post will give best results. A rock tip is available to fit 4" (100mm) and 6" (150mm) augers for digging in extremely hard conditions, including some types of rock. It should be noted however, that progress would be significantly slower when digging in rocky conditions with this tip.

With the post position determined, the post can be placed under the hammer and held in position with the special crow bar provided. The hook end of the crow bar is engaged in an appropriate link of the chain. The bar is then pulled against the post to hold it in the desired position whilst it is being driven in.

When using steel (railway-iron) and/or concrete fence posts with your Power House post driver, a mild steel cap must be used on top of the iron post to prevent impact damage to the hammer bottom plate. A rubber pad is available from manufactures of concrete posts to reduce the shock at impact. If these are not used warranty will be void for weld cracking and/or impact damage to the hammer.



Figure 7 - Driving a Post

Note: Do not place the chain in the chain hook on the mast when driving in posts. The chain hook must only be used for storage of the post driver.

Posts longer than 8 ft. (2.4m) can be driven by fitting an optional extension foot. This extension foot can be attached to the base of the post driver if a considerable number of posts over 8ft. (2.4m) are going to be driven.

NOTE: Contact the Parts and Service Division for further information on the optional extension foot. Also note, a Highlift option is available, see page 18.

CAUTION: Keep feet clear of post driver base when lowering the post driver using the tractor's three point linkage arms.

SAFTY INSPECTIONS, MAINTENANCE AND SERVICING SCHEDULE.

The following safety inspections, maintenance & service schedule has been developed to ensure that the Post Driver delivers safe & reliable service for the owner.

Item / Component.	Safety Inspection frequency	Lubrication details
Guards – check for correct operation & integrity of all covers & guards.	Daily	None.
Pins – check all lynch pins for integrity, top link pins, 3-point linkage pins, Mast pivot pin.	Daily	None.
Hydraulic hoses – check all hydraulic hoses and fittings for abrasion to outer sheath and integrity of fittings.	Daily	None.
Correct operation of the control valve.	Daily	None.
Top link & tilt cylinder – check rod ends for integrity & cracks.	Daily	None.
Safety & Warning stickers – check for integrity & legibility.	Daily	None.
All bolts & fasteners for integrity & correct tension including: <ul style="list-style-type: none"> • Bolt on lift cylinder rod to hammer frame mount. • Bolts on slide rod to mast. • Cap screws of Auger carrier ramp to mast. • Cap screws of auger motor to pedestal drive plate. 	Weekly	None.
Pivot bolt to “A” frame & radius plate.	Weekly	Grease to slide.
Hammer frame to mast guide pads for wear.	Weekly	Grease daily.
Mast Pivot	Daily	Grease – weekly
Auger carrier guide rod	Daily	Grease upon use
Auger carrier latch assembly, linkages & bushes etc.	Weekly	Oil.

NOTE: Contact Lyco - Parts and Service Division for technical assistance for the servicing of your post driver. See page 21 for address details.

OPTIONS

HIGHLIFT

The highlift option is available to provide extra hammer height, allowing for the driving of longer posts, up to 12' (3.65m). The highlift attaches to the three-point linkage of the tractor, with the titling facilities still available. The standard post driver is connected to the highlift, as shown in Figure 8 below.



Figure 8 - Highlift Option

The highlift has a double acting cylinder that raises the post driver mast off the ground to the required height. The cylinder can then be lowered, thus lowering the mast, as the post is being driven in.

NOTE: When using the No.1 Highlift with Side Shift the total weight is 1105kg. Check the tractor specifications before operating.

SIDE-SHIFT

The side shift comprises two basic parts, the main frame and the sliding carriage. The tractor's top link is adjusted so that the frame is in a vertical position with the post driver resting on the ground. It is recommended that category 2 is a minimum requirement to efficiently handle the loads applied to the linkage.

The hydraulically operated carriage slides across the main frame and is operated by an additional spool on the post driver control valve. The flexible hydraulic lines to the cylinder are fitted with male and female hose ends in order that they can be coupled together if the post driver is used without the side shift. The post driver attaches to the carriage by using category 1 linkage clevis on the A-Frame and the 8" top link cylinder. All necessary lynch-pins are provided for this purpose. A 7ft. (2.1m) pressure hose and 15ft. (4.5m) return hose are also provided. Adjust the stabiliser chains on the tractor linkage arms to eliminate side movement of the frame.

The post driver may be extended beyond the line of the near side rear wheel of the tractor when attached to the side shift (in normal wheel track situations). This operation is controlled by the control handle on the post driver nearest the side shift. It may be operated with the linkage either partly raised or with the driver resting on its base plate.

Note: **Keep feet clear of the Side Shift** if the side shift unit is raised on the three point linkage arms of the tractor.



Figure 9 - Side Shift Option

If the post driver is in contact with the ground it is desirable to tilt the machine so that the leading edge of the base plate is just clear of the surface to be traversed, otherwise bogging may occur. This will place considerable side load on the linkages. Always check the mast for vertical position prior to shifting to the transport position (carriage cylinder fully retracted). This is necessary particularly when a 10" auger is attached to avoid colliding the auger with the main frame. In the transport position the mast may be tilted to close up the top link cylinder and centralise the load. The auger cannot be attached to the hammer unless the carriage is in the extended or work position, as there is insufficient space. The side shift enables the post driver to be adjusted so as to position the auger and/or post on the sight line, the amount of side adjustment past the wheel being regulated by the size of the rear tyres and also the wheel track width.

SPECIFICATIONS

MINIMUM HYDRAULIC REQUIREMENTS 17 l/min. @ 2000 P.S.I.

HAMMER WEIGHT 535 LBS. (244 kg)
 Optional heavy Hammer 640 LBS. (291 kg)

APPROXIMATE POTENTIAL ENERGY 2250 lbft. (3052 Nm)

MAXIMUM POST LENGTH 9 ft. (2.7m)
 with machine lifted up on optional extension feet.

FOR HIGHLIFT OPTIONS 12 ft. (3.65m) for Highlift

AUGER MOTORS AVAILABLE

NOTE Optimum rotational speed of auger is in the range of 100 - 150 rpm. To achieve this range the auger motor size should be matched to tractor hydraulic flow rates.

SIZE	E	G	K
THEORETICAL TORQUE @ 2200 P.S.I.	3520 in.lb (398 Nm)	4378 in.lb (495 Nm)	5412 in.lb (612 Nm)
MIN/MAX FLOW RANGE l.p.m. (G.P.M.- U.S.)	17 lpm 25 4.5 GPM 6.6	20 lpm 30 5.3 GPM 7.9	25 lpm 38 6.6 GPM 10
RPM @ MIN/MAX FLOW	104 RPM 153	100 RPM 150	100 RPM 152

AUGER SIZES AVAILABLE

2" (50mm), 3" (75mm), 4" (100mm), 5" (125mm), 6" (150mm), 7" (175mm), 8" (200mm), 10" (250mm), 12"(300mm)

- Other sizes made to order

TILTS

Fore & aft tilt: 6" top link cylinder, 8° either side of vertical
 8" top link cylinder, 12.5° either side of vertical
 Side tilt: 13° either side of vertical

SERVICE AND REPAIR

Your Lyco Post Driver is manufactured to the highest possible standards and is well tested before it leaves our factory. However, if the driver does not function as it should, carefully follow the procedure below.

1. Examine the driver in operation and accurately note down the exact area and description of the problem using the correct part names.
2. Also note unfamiliar noises or functions that could aid in problem diagnosis (minor details are important).
3. Make note of the driver Serial No. - located on top of the A-Frame.
4. Phone Lyco Innovations Parts and Service Division with handbook, serial number, and notes of the problem handy to you.

Munro Engineers Pty. Ltd.

418-420 Winter St

Ballarat 3350

Telephone: +61 3 5334 2770

Fax: +61 3 5334 2755

Email: sales@munroeng.com

Website: www.munroeng.com

It is necessary to follow this procedure so that our service technicians may quickly solve any malfunction that may exist either by minor adjustment or changeover part.

A comprehensive range of spare parts and consumable parts are available, including: augers, tips, seal kits and wear pads. Contact the Parts & Service Division for further assistance.

INDEX

A

A-Frame · 10, 14, 19, 22
auger · 1, 12, 13, 14, 20, 21

C

crow bar · 15
cylinder · 9, 10, 14, 19, 20

F

filler plug · 7, 8
flow rates · 21

G

grease · 12
guard · 9

H

hammer · 12, 13, 14, 15, 18, 20
highlift · 18

hose · 7, 19

M

mast · 9, 12, 14, 20

P

Parts and Service · 1, 22
post holes · 1

S

side shift · 19, 20
stroke · 9, 10, 12, 14

T

tilt · 10, 14, 20

V

valve · 11, 12, 13, 19



“PowerHouse” Post Hole Auger & Post Driver

INSTRUCTION MANUAL

Munro Engineers Pty. Ltd.

418-420 Winter St

Ballarat 3350

Telephone: +61 3 5334 2770

Fax: +61 3 5334 2755

Email: sales@munroeng.com

Website: www.munroeng.com

Manufactured by Lyco Innovations Pty Ltd